

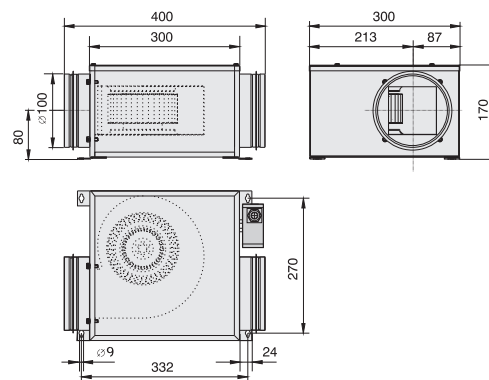

Typ / Type : <b>Z 100 U</b>		Art.-Nr. / Art.-No. : <b>F05-10015</b>	
U	230V (50Hz)	$\Delta p_{fa}$ min	-- Pa
P <sub>1</sub>	0.074 kW	$\Delta I$	-- %
I <sub>N</sub>	0.32 A	I <sub>A</sub> / I <sub>N</sub>	1.5
n	2340 min <sup>-1</sup>		IP44
C <sub>400V</sub>	2.0 $\mu$ F		01.009
t <sub>R</sub>	70 °C		7.0 kg



LWArel A-bewertet bei V=0,5*Vmax LWArel A-weighted at V=0,5*Vmax		fM [Hz]						
		125	250	500	1K	2K	4K	8K
LWA2 [dB(A)]	Gehäuse / casing	32	34	33	29	28	26	22
LWA5 [dB(A)]	Ansaugseite / inlet side	35	37	35	34	30	29	24
LWA6 [dB(A)]	Ausblasseite / outlet side	48	55	55	57	57	54	45